

**83mm flat burrs**

**MM**  
**MM**  
**MAZZER®**

**Major/V** *electronic*

DESIGNED FOR **#MaxSpeed** with **#FlatBurrs**

# ELECTRONIC CONTROL PANEL



**19 LANGUAGE Control Panel** with wide viewing angle

>160° Pannello di controllo ergonomico configurabile in 19 lingue



Total and partial dose **COUNTER**  
**CONTATORE** dosi totale e parziale

Ability to set up a **MAXIMUM DOSE CAP**  
Possibilità di impostare il **NUMERO MASSIMO DI DOSI** macinabili

**PROGRAMMABLE** single, double, and triple dose buttons. Steps of a hundredth of a second.  
Configurazione tempi di macinatura per **DOSE SINGOLA, DOPPIA e TRIPLA**.  
Precisione al centesimo di secondo.

**MANUAL GRINDING** mode  
Modalità **MACINATURA MANUALE**

Daily grinding **STATISTICS**  
**STATISTICHE GIORNALIERE** sui dati di lavoro

Programmable **PAUSE FUNCTION**  
in between grinding  
Funzione pausa di macinatura programmabile

**FIRMWARE UPGRADES** option  
Possibilità **AGGIORNAMENTO FIRMWARE**

**ALERTS** on service needs, worn burrs  
**NOTIFICHE** di servizio, alert cambio macine

## CUTTING EDGE TECHNOLOGY - FLAT BURRS

Inside and out, the Major V features many performance and styling upgrades. New sharper and compact design, precision machined components, metal accessories, and high-tech electronics

GFC

Keep grounds from getting on the counter ( **ELECTROSTATIC CHARGE REDUCTION** ) while getting **UNIFORM COFFEE GROUNDS** in your portafilter with the innovative GFC System. GFC - Grind Flow Control consists of a removable aluminum outlet insert equipped with two interchangeable wire dampers (AntiDust and Hybrid).

NO  
WASTE

**LOW RETENTION.** Save coffee and time



No loss of grind settings with **EASY TO CLEAN** grinding chamber



User friendly **MEMORY TRACK** system to index grind setting. **MORE PRECISE**, wider grinding adjustment range



On-demand grinding can be **EASILY ACTIVATED** with the portafilter



**DOUBLE FAN** cooling system



**ADJUSTABLE PORTAFILTER HOLDER.** Grind hands-free and consistently center the flow of grinds in your basket



### IoT. Be Connected Unlock new possibilities

Wherever you are, be connected to your grinder on your cloud. Thanks to the internet-connectable platform data about your grinder is remotely easily accessible by barista, coffee roaster, business owner or service. You'll be able to monitor any and all of your grinders' output, keep up with maintenance needs, and improve the quality of your coffee in a scientific way using data tracked by the grinder (optional).



## TECNOLOGIA D'AVANGUARDIA, MACINE PIANE

**Nuovo design** solido e compatto. Finiture premium, componenti realizzati con lavorazioni meccaniche di precisione, accessori in metallo, elettronica high-tech

GFC

**MINIMA DISPERSIONE** di caffè sul bancone (abbattimento carica elettrostatica) e **MACINATO OMOGENEO** grazie all'innovativo sistema **GFC - Grind Flow Control** composto da una bocchetta estraibile in alluminio equipaggiata con due regolatori di flusso intercambiabili (AntiDust e Hybrid).

NO WASTE

**BASSA RITENZIONE** con la camera di macinatura a geometrie ottimizzate per un risparmio di tempo e caffè.



**FACILE PULIZIA** della camera di macinatura senza perdita del settaggio



Ghiera con legenda **MEMORY TRACK**  
Campo di regolazione più ampio per una maggior precisione



**MACINATURA on-demand ATTIVABILE CON LA COPPA** portafiltro



**SISTEMA DI RAFFREDDAMENTO** con doppia ventola



**SUPPORTO PORTAFILTRO MULTI-REGOLABILE** per un pratico aggancio della coppa durante la macinatura e una migliore centratura del caffè



**IoT. RESTA CONNESSO e aperto a nuove possibilità**

Ovunque tu sia, accedi in tempo reale al tuo report di macinatura sul cloud. Grazie a una piattaforma che può essere connessa a internet i dati di macinatura saranno consultabili in remoto da barista, torrefattore, proprietario del coffee shop o servizio tecnico. Sarai in grado di monitorare le statistiche di utilizzo dei tuoi macinacaffè sul tuo device, di programmarne la manutenzione e di migliorare costantemente la qualità del tuo espresso analizzando i parametri in modo scientifico (optional).



# MAJOR V electronic Tech Specs

## EN

*Grinding on demand, electronic dose adjustment, ventilation with electronic control*

Power	650 Watt
Grinding adjustment	stepless micrometrical
Burrs	flat burrs 83 mm (ref. 151A)
Grinding burrs speed	1400 rpm (50 Hz) - 1600 rpm (60Hz)
Body	aluminum die casting
Hopper capacity	1.6 kg (3.5 lbs)
Net weight	20.5 kg (45.2 lbs)
Equipment feature	GFC Kit
Optional features	IoT, ref. T151A burrs, hand tamper in aluminum with support base

## FR

*Mouture instantanée, réglage électronique de la dose, ventilation électronique*

Puissance	650 Watt
Régulation de mouture	micrométrique continue
Meules	meule plate - 83 mm (ref. 151A)
Tours meules	1400 tr/min (50 Hz) - 1600 tr/min (60Hz)
Chassis	aluminium moulé sous pression
Trémie	1.6 kg
Poids net	20.5 kg
Dotation	GFC Kit
Options	IoT, meules réf. 151A, Tasseur à café manuel en aluminium avec support

## ES

*Moledura instantánea, regulación electrónica de la dosis, ventilación electrónica*

Potencia	650 Watt
Regulación molienda	micrométrica continua
Fresas	muela plana 83 mm (ref. 151A)
Revoluciones fresas	1400 rpm (50 Hz) - 1600 rpm (60Hz)
Chassis	fundición a presión de aluminio
Capacidad de la tolva	1.6 kg
Peso neto	20.5 kg
Incluido	GFC Kit
Opciones	IoT, muelas ref. 151A, Prensa café de aluminio con soporte

## IT

*Macinatura istantanea, regolazione elettronica della dose, ventilazione elettronica*

Potenza	650 Watt
Regolazione macinatura	micrometrica continua
Macine	piane - 83 mm (rif. 151A)
Giri macine	1400 rpm (50 Hz) - 1600 rpm (60Hz)
Carrozzeria	alluminio pressofuso
Campana	1.6 kg
Peso netto	20.5 kg
Di serie	GFC Kit
Optional	IoT, macine rif. T151A, Pressino manuale in alluminio con supporto

## DE

*Augenblickliches Mahlen, Elektronische Einstellung der Dosis, Elektronisch-kontrollierte Luftung*

Leistung	650 Watt
Mahlregelung	Stufenlose Mikrometrische
Mahlscheiben	Scheibenmahlwerk flach 83mm (ref. 151A)
Mahlscheibenumdrehungen	1400 rpm (50 Hz) - 1600 rpm (60Hz)
Gehäuse	Aluminium Druck-Guss
Kapazität des Bohnenbehälters	1.6 kg
Nettogewicht	20.5 kg
Lieferumfang Zubehör	GFC Kit
Optional	IoT, Mahlscheiben ref. 151A, Tamper aus Aluminium mit Kaffeepressengestall

## PT

*Moagem instantânea, regulação eletrônica de dose, ventilação eletrônica*

Potencia	650 Watt
Regulação da moagem	micrométrica contínua
Mós	mós planas 83 mm (ref. 151A)
Rotações dos mós	1400 rpm (50 Hz) - 1600 rpm (60Hz)
Chassis	alumínio fundido sob pressão
Capacidade tremonha	1.6 kg
Peso líquido	20.5 kg
Incluído como padrão	GFC Kit
Opções	IoT, mós ref. 151A, Calcador de café de alumínio con soporte

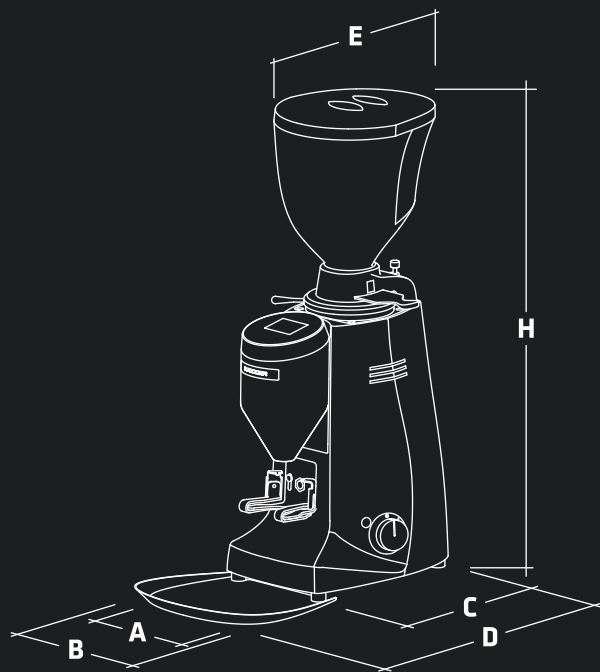

**Stepless micrometrical grind adjustment**  
Sistema di regolazione macinatura micrometrica continua



**SECURITY FEATURES**  
Sistemi di protezione

## dimensions

	mm	inches
A	212	8 1/2
B	252	10
C	292	11 1/2
D	475	18 3/4
H	681	26 3/4
E	240	9 1/2



**83mm**  
flat burrs

## colours

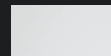

**pure white**  
bianco neve



**matt black**  
nero opaco



**matt gray**  
grigio opaco



**silver**  
grigio chiaro

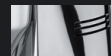

**polished aluminum**  
alluminio lucidato



**bright red**  
rosso ciliegia

## certifications



The manufacturer reserves the right to change specifications without notice

Il costruttore si riserva la facoltà di apportare modifiche senza preavviso

**MAZZER LUIGI S.p.a.**  
Via Moglianese Gardigiano 113  
30037 Scorzè (VE) - Italy  
Tel.: +39 041 5831300  
mazzer@mazzer.com  
www.mazzer.com

@mazzerofficial

**MM**  
**MAZZER**

**Made in Venice**

DPMJELC042021